

The background of the slide is a dark, textured surface covered with hazelnuts. Some hazelnuts are whole, showing their characteristic reddish-brown, smooth shells. Others are cracked open, revealing the light brown, textured inner nutmeat. The lighting is soft, highlighting the natural textures and colors of the nuts.

# PROJECT 3.1 HAZELNUT DRYING PROGRESS

Dr Yong Wang

School of Chemical Engineering, UNSW

Oct 2025

## Background and project summary

- Turkey's post-harvest techniques are optimized for **large-scale, humid, mountainous coastal regions**.
- Australia's hazelnut orchards are smaller and often located in varied, drier regions like NSW and Victoria. That means **different drying behaviour and storage needs**, requiring localized post-harvest solutions.



# Background and project summary (2024-25)



## Primary Goal:

- To design, construct, and validate a post-harvest drying system optimized for hazelnuts.

## Feature

- Scalable, low-cost, energy-efficient, real-time monitoring drying system tailored to Australian conditions.

## Specific Objectives:

- Achieve uniform moisture reduction without quality degradation.
- Enable real-time monitoring of drying conditions via IoT integration.
- Demonstrate off-grid operation using solar photovoltaic systems.
- Investigate drying kinetics and nutritional changes.
- Low cost.



## Topics to cover



1. Literature review

2. Hot-air drying

3. Solar drying lab scale

4. Next steps

# Drying temperature

Table 1. Recommended drying temperature of in-shell hazelnuts.

Temperature (°C)	Reference
40	Tous, 2005 <sup>[59]</sup>
30 – 40	Wang et al., 2018 <sup>[7]</sup> , Ozay et al., 2008 <sup>[46]</sup> , Lopez et al., 1998 <sup>[69]</sup>
32 – 38	Snare, 2008 <sup>[48]</sup>
35 – 40.6	Olsen et al., 2002 <sup>[70]</sup>
40 – 50	Lopez et al., 1997 <sup>[54]</sup> , Lopez et al., 1998 <sup>[57]</sup>
45 – 50	Turan, 2018 <sup>[5]</sup> , Turan, 2018 <sup>[55]</sup>

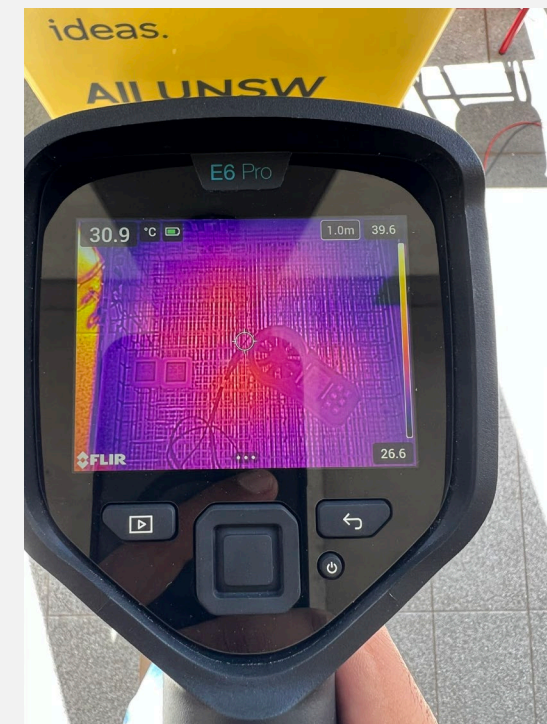

## Targeted final moisture

Table 2. Recommended moisture content of hazelnuts (in-shell and kernel) after drying.

- Moisture level is a major element in hazelnut quality as fresh nuts may decay within days after harvest.
- Above a certain threshold, water activity causes mould, colour changes, and rancidity.

Moisture content (%)		Reference
In-shell	Kernel	
-	3.5 – 5	Ghirardello et al., 2013 <sup>[77]</sup>
7 – 8	4 – 5	Lopez et al., 1998 <sup>[57]</sup>
-	≤ 5	Olsen et al., 2002 <sup>[70]</sup>
10 – 12	6 – 7	Gross et al., 2016 <sup>[76]</sup>
7	-	Tous, 2005 <sup>[59]</sup>
8 – 9	-	Martín et al., 2001 <sup>[73]</sup>
10	-	Vrtodušić et al., 2002 <sup>[74]</sup>



## Topics to cover



1. Literature review

2. Hot-air drying

3. Solar drying lab scale

4. Next steps

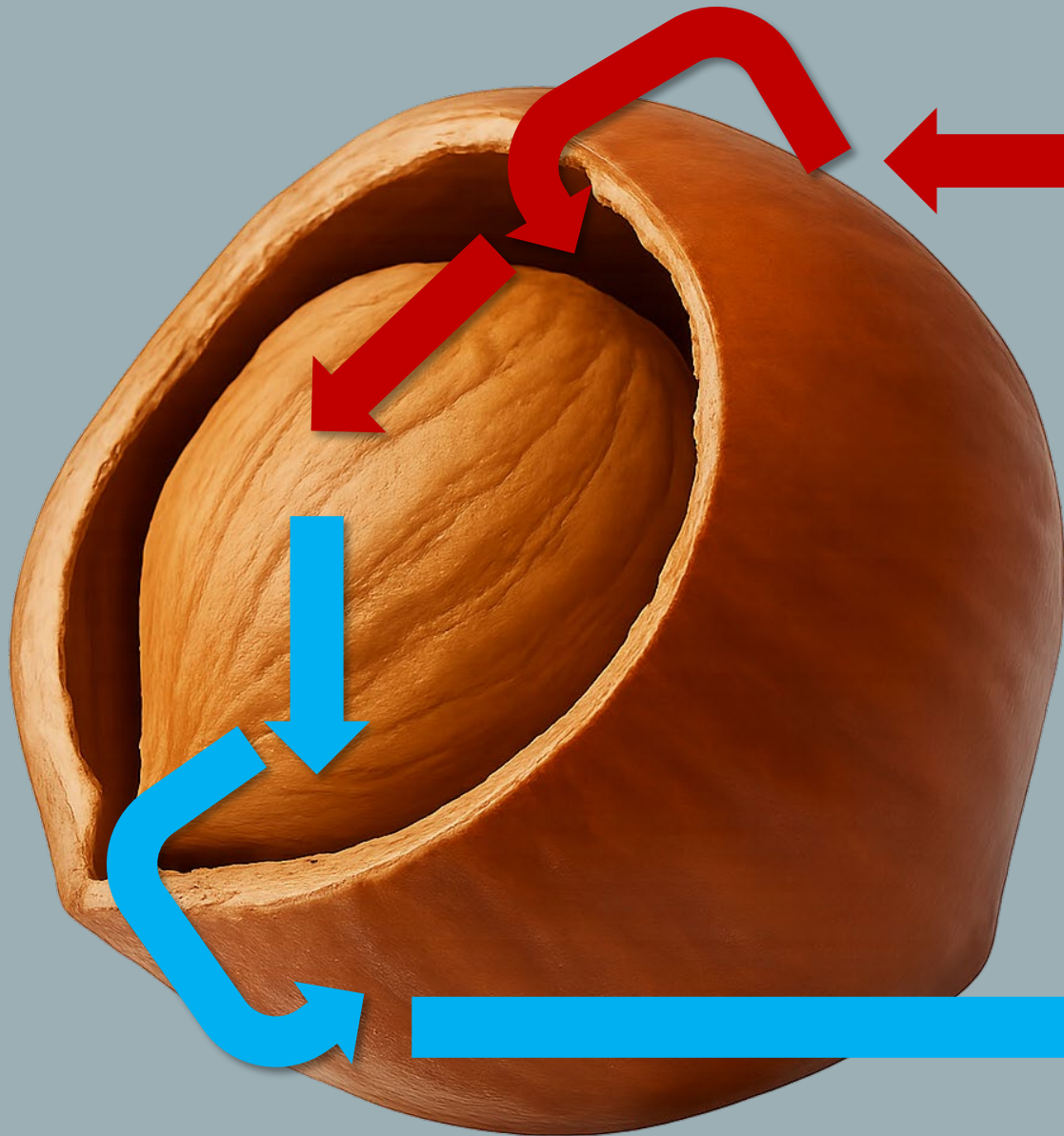

Heat transfer

What happens during drying hazelnuts?

Moisture transfer

# Drying time is limited by ...

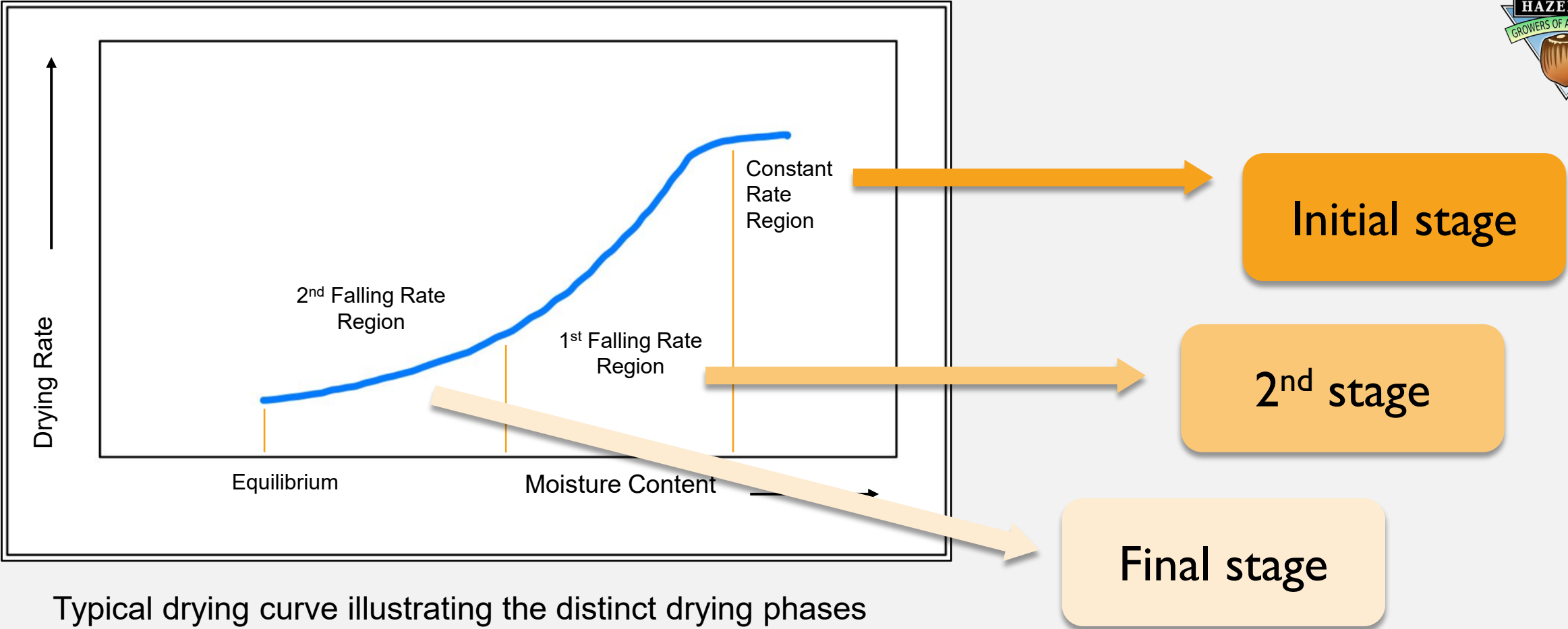

Typical drying curve illustrating the distinct drying phases for porous materials

# Hot-air drying rate at different temperature

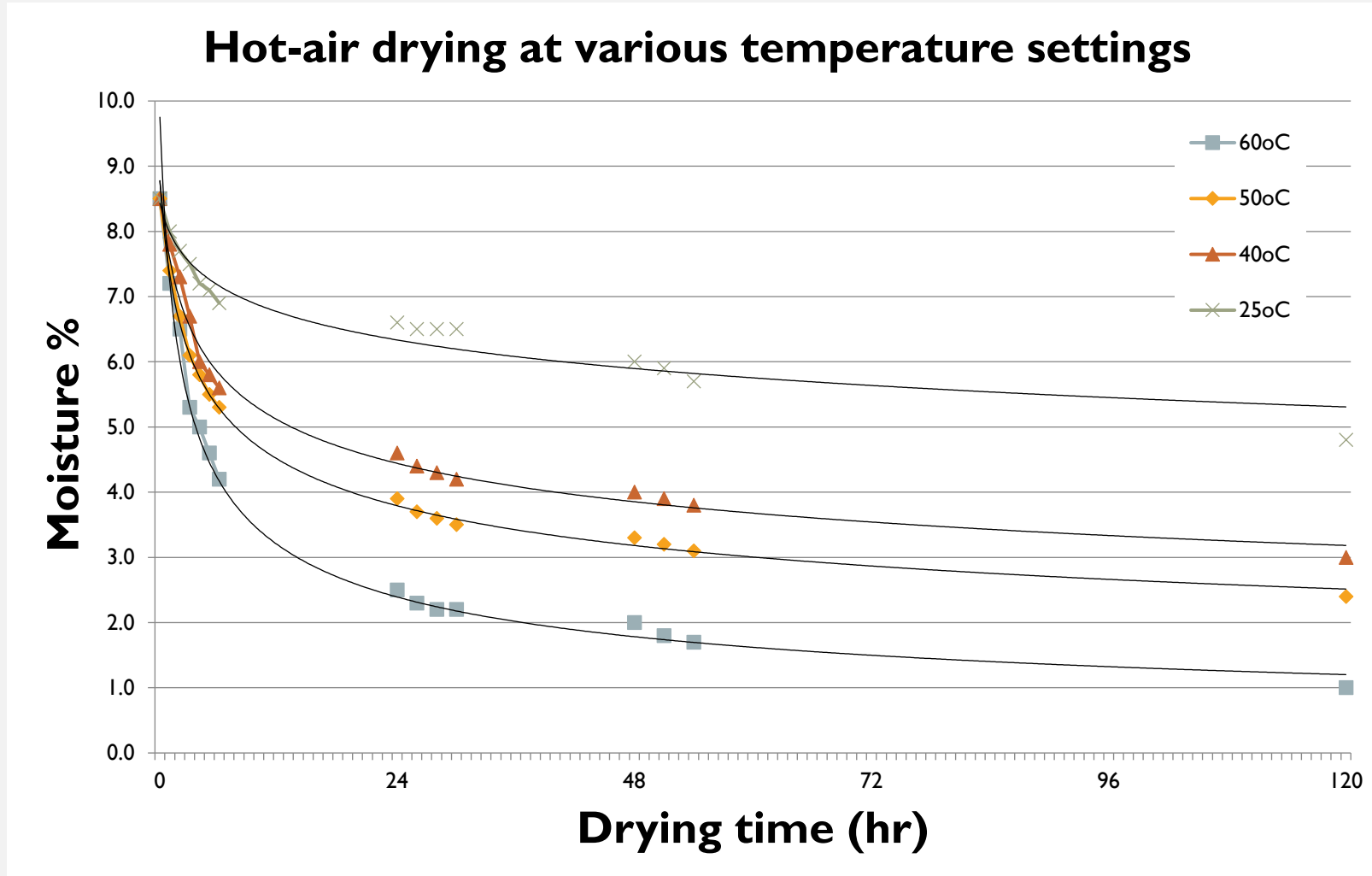

Table I. Time required to reach 5%\* moisture content of hazelnut kernels after hot-air drying.

Hot-air oven temperature (°C)	Time
60	4hr 44min
50	8hr 43min
40	14hr 32min
25	195hr 46min

\*Note: 5% moisture content is used for comparison only.

Figure 1. Moisture content of hazelnuts after hot-air drying at various temperature settings.

# Can we make it faster?

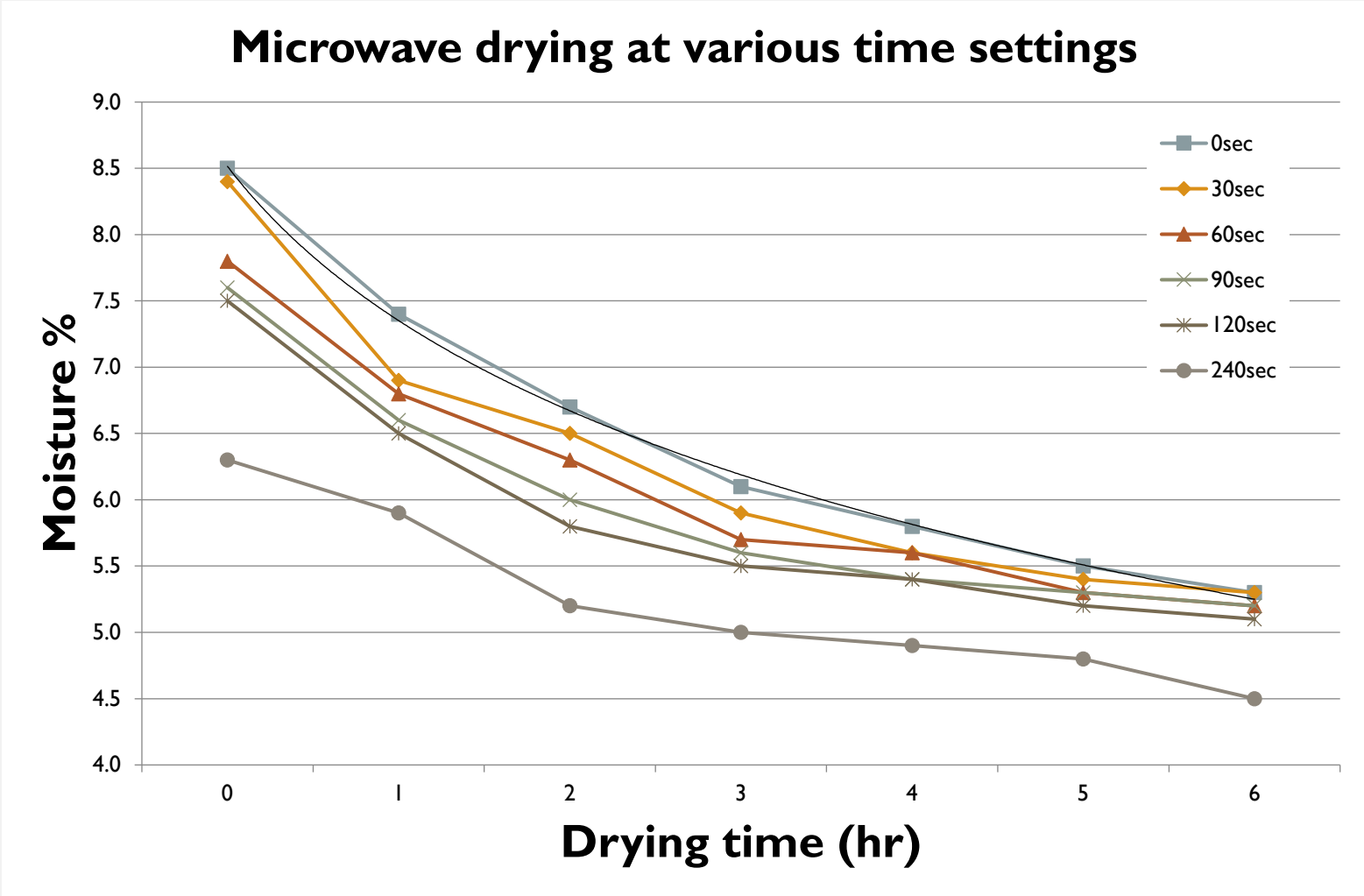

Table 2. Time required to reach 5%\* moisture content of hazelnut kernels after microwave drying and HA drying.

Microwave drying time (sec)	Time
0	8hr 12min
30	7hr 36min
60	7hr 37min
90	7hr 14min
120	6hr 46min
240	4hr 21min

\*Note: 5% moisture content is used for comparison only.

Figure 2. Moisture content of hazelnuts after microwave drying at various durations at 50°C.



## Topics to cover



1. Literature review

2. Hot-air drying

3. Solar drying lab scale

4. Next steps

# Lab-scale solar dryer design

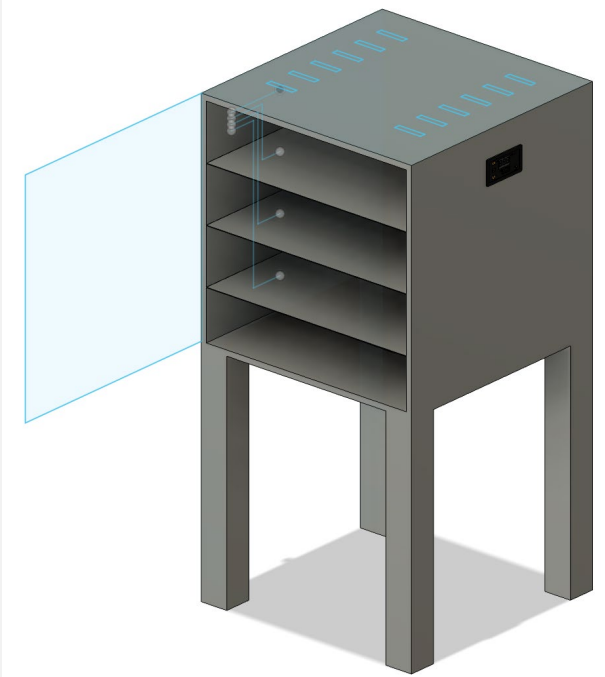
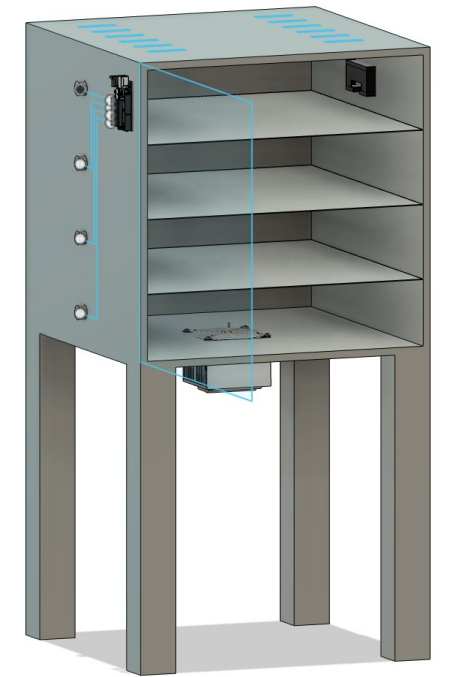

(A) (B) Isometric front views

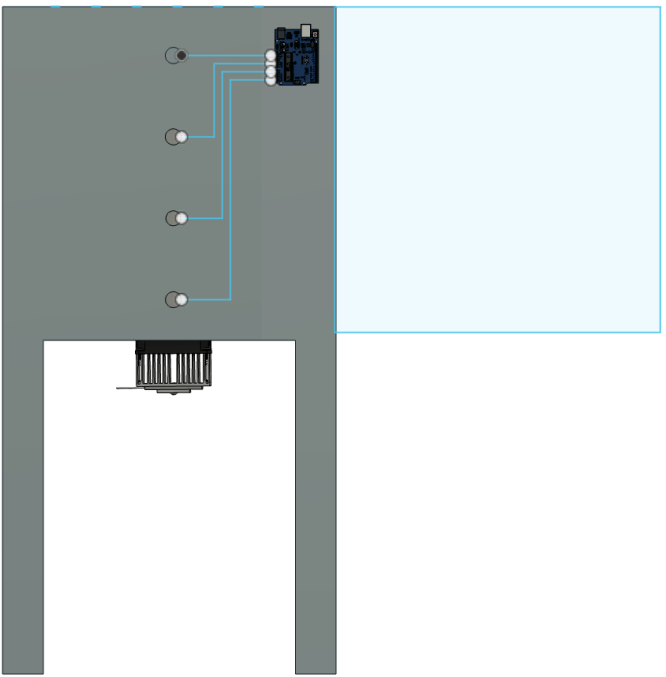

(C) Left View

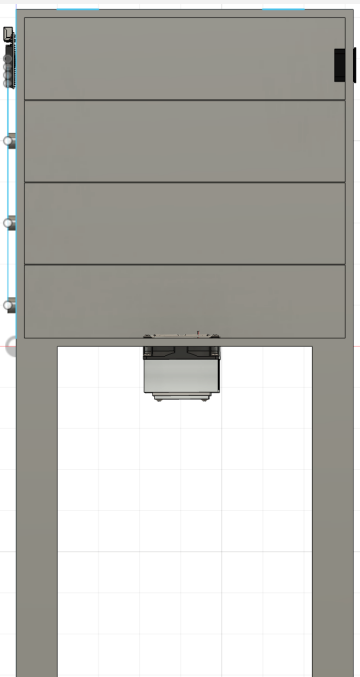

(D) Frontal elevation

# Lab-scale solar dryer design

- Prototype



(A) Final Prototype

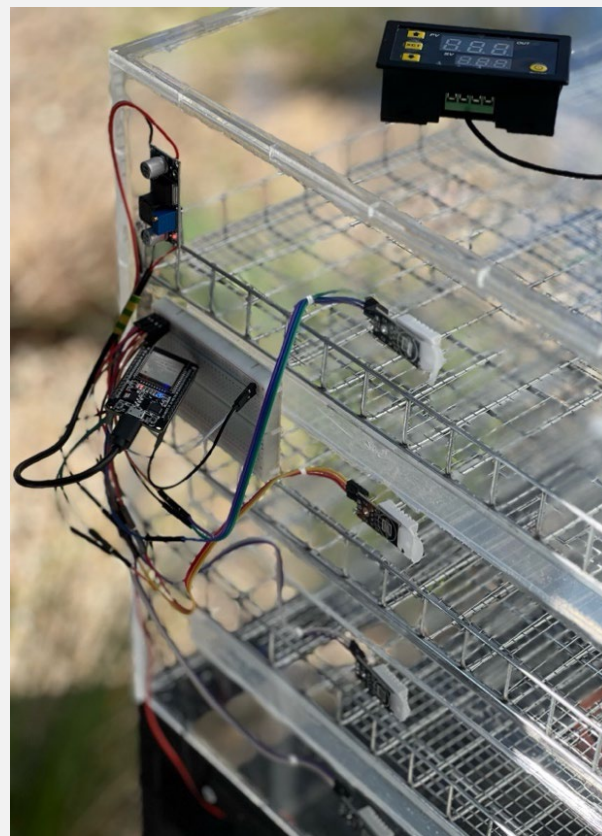

(B) Electronics

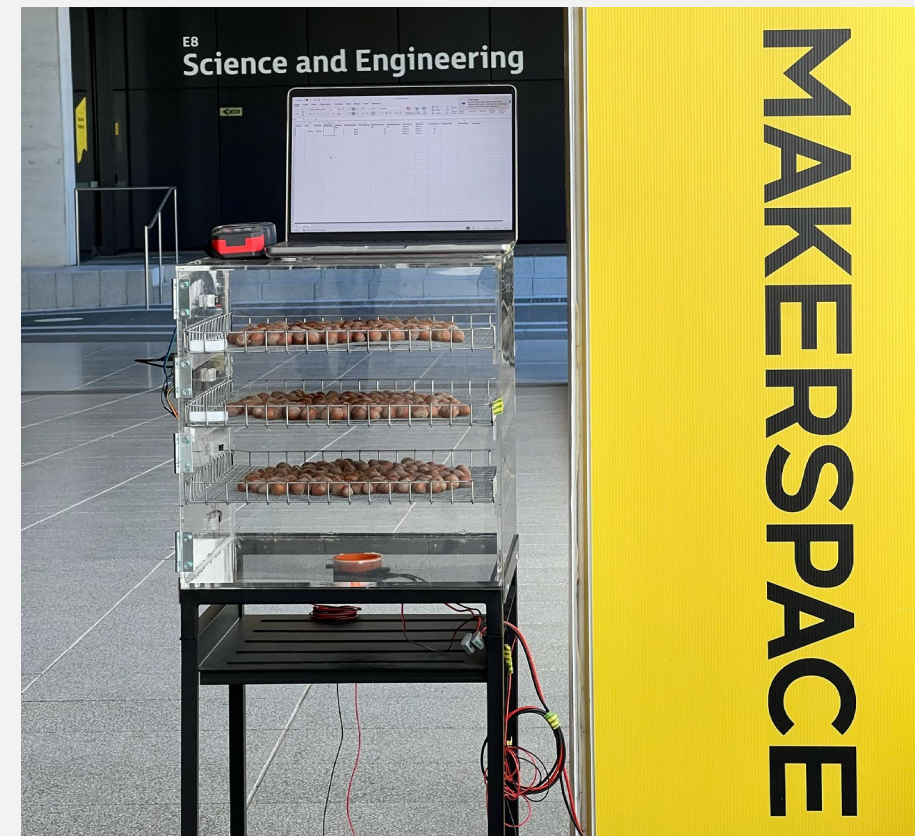

(C) Trial Phase

# 3D-Printed Fan Adapter

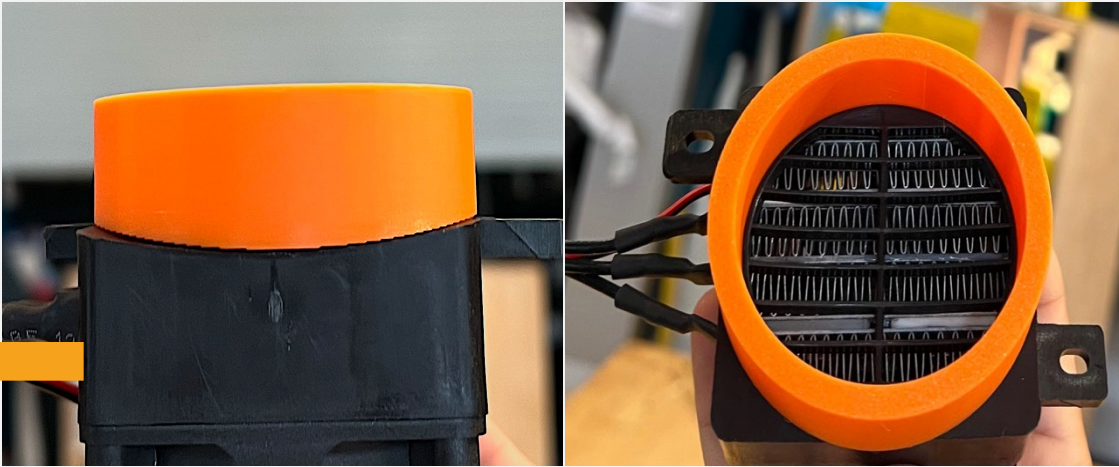
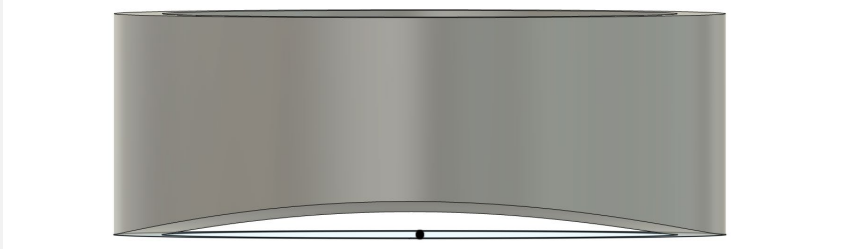
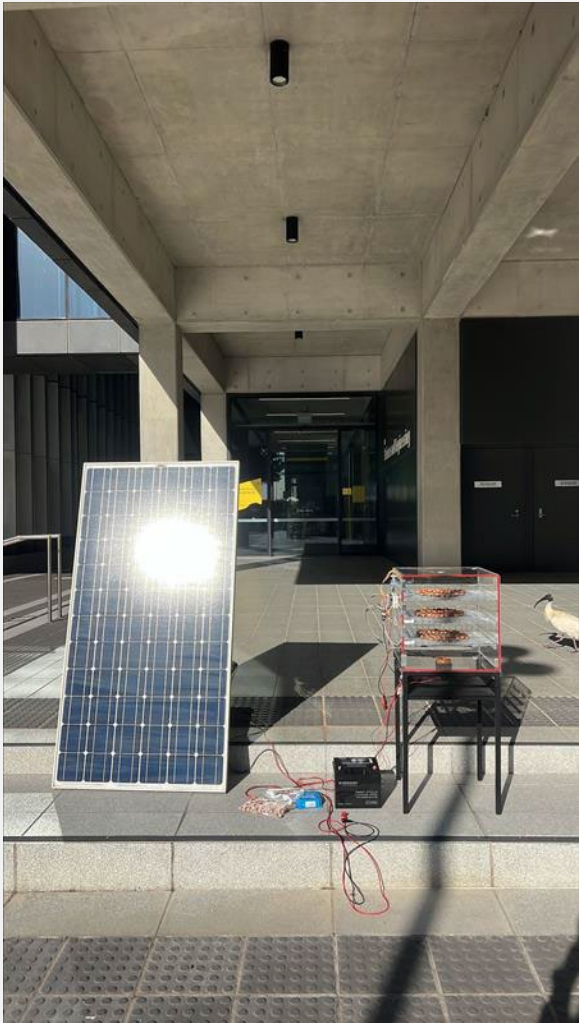

CAD design and 3D-printed adapter for securely mounting the curved PTC fan, ensuring stable airflow in the drying chamber.

# Sensor and IoT System

## Sensor Setup

- Seven DHT22 sensors
- One DS18B20 sensor

## Sensor Placement

- Four sidewall-mounted
- One top-mounted DHT
- Two corner DHT22 (to
- DS18B20 near air inle

## IoT Integration

- ESP32 microcontroller
- Data logged via Thing

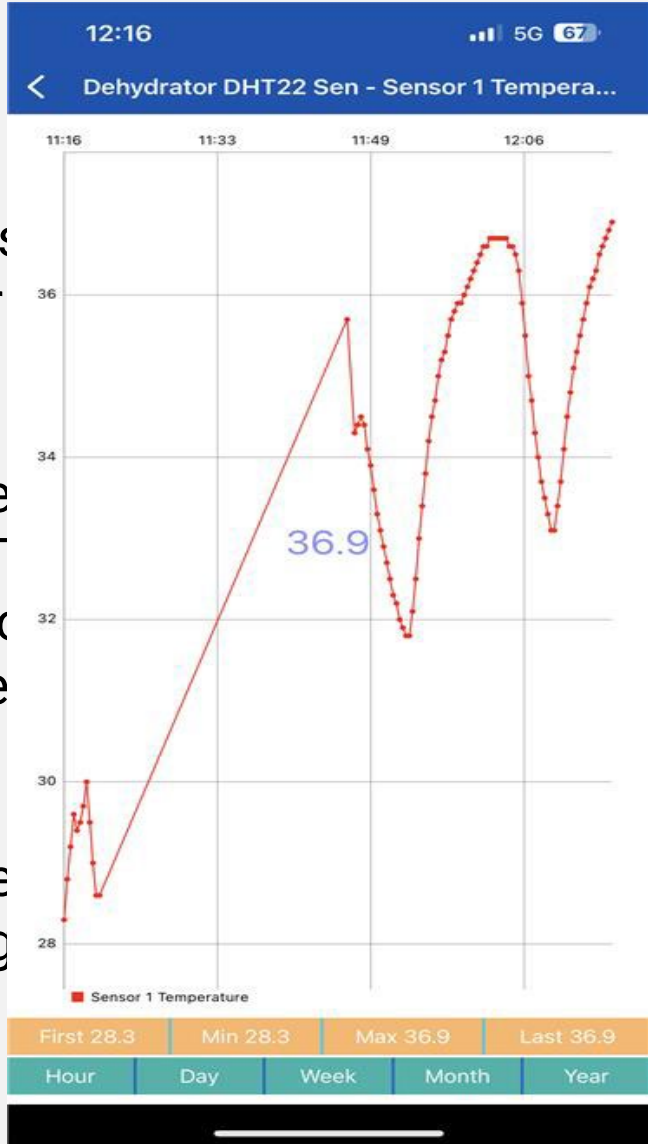

H: 0–100%).

ping.

tion.

with all sensors.  
monitoring.

- DHT22

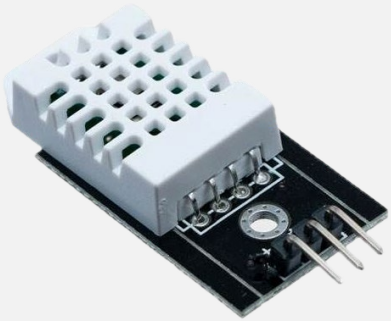

- DS18B20

- ESP32

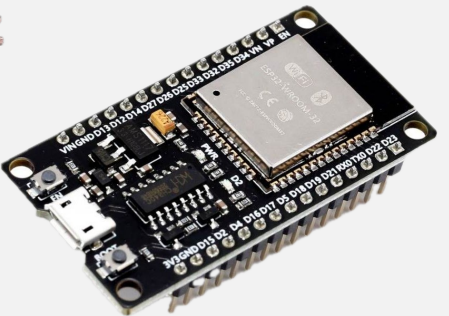

# CFD Simulation

## Simulation Setup

- Conducted using COMSOL Multiphysics 6.1.
- Chamber geometry modeled with mesh grids and boundary conditions.

## Key Simulations:

- Airflow pattern visualization.
- Identification of hot, cold and recirculation zones.
- Testing different hazelnut placement and outlet configurations.





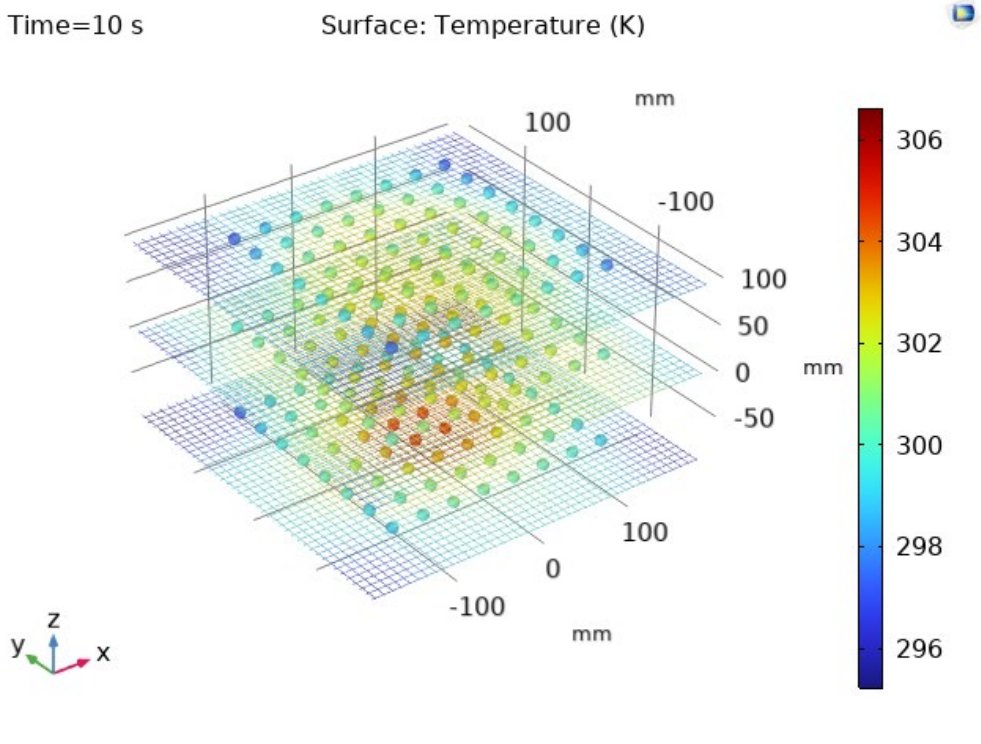
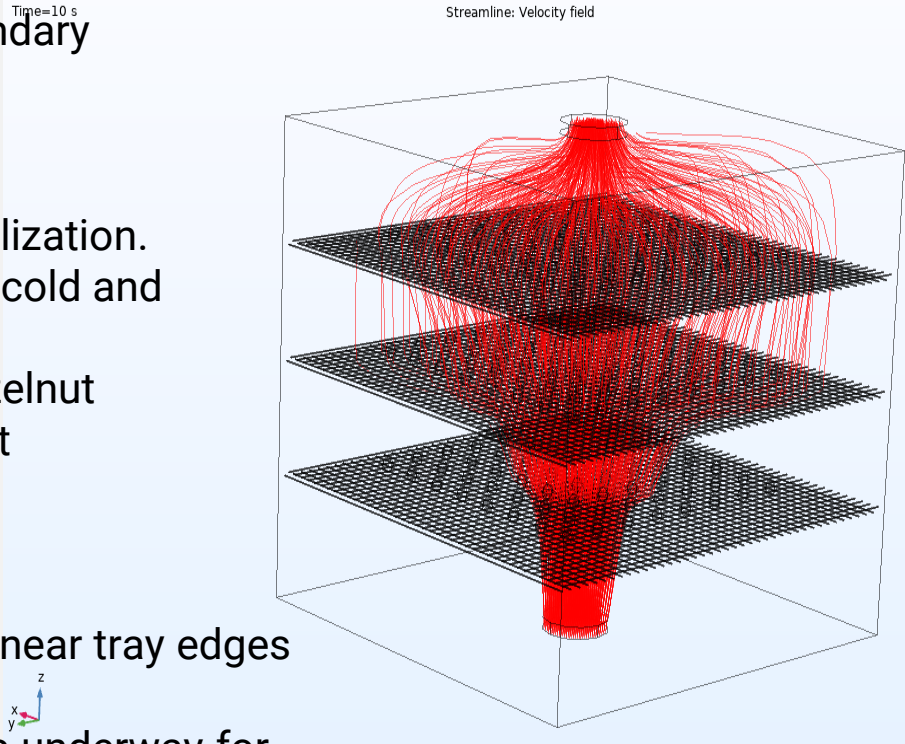



## Preliminary Results:

- Non-uniform airflow near tray edges identified.
- Design optimizations underway for enhanced drying uniformity.



# Shell cracking caused by drying

*Table 1 - Shell cracking (%) in hazelnuts across drying treatments (n = 3).*

Treatment Temp.	Replicate 1	Replicate 2	Replicate 3
<b>105° C</b>		No Cracking	
	1.8g / 200g 0.90% (w/w)	0g / 200.1g 0.00% (w/w)	5.6g / 200.2g 2.80% (w/w)
<b>80° C</b>			
	12.3g / 200g 6.15% (w/w)	9.1g / 200.6g 4.54% (w/w)	12.5g / 200.1g 6.25% (w/w)
<b>60° C</b>		No Cracking	No Cracking
	10g / 200.6g 4.99% (w/w)	0g / 200.5g 0.00% (w/w)	0g / 200.6g 0.00% (w/w)
<b>50° C</b>			

*Figure 16 - Shell cracking % (w/w) of hazelnuts across different drying temperatures. Each data point represents the mean ± SEM (n = 3).*

# Shell after drying

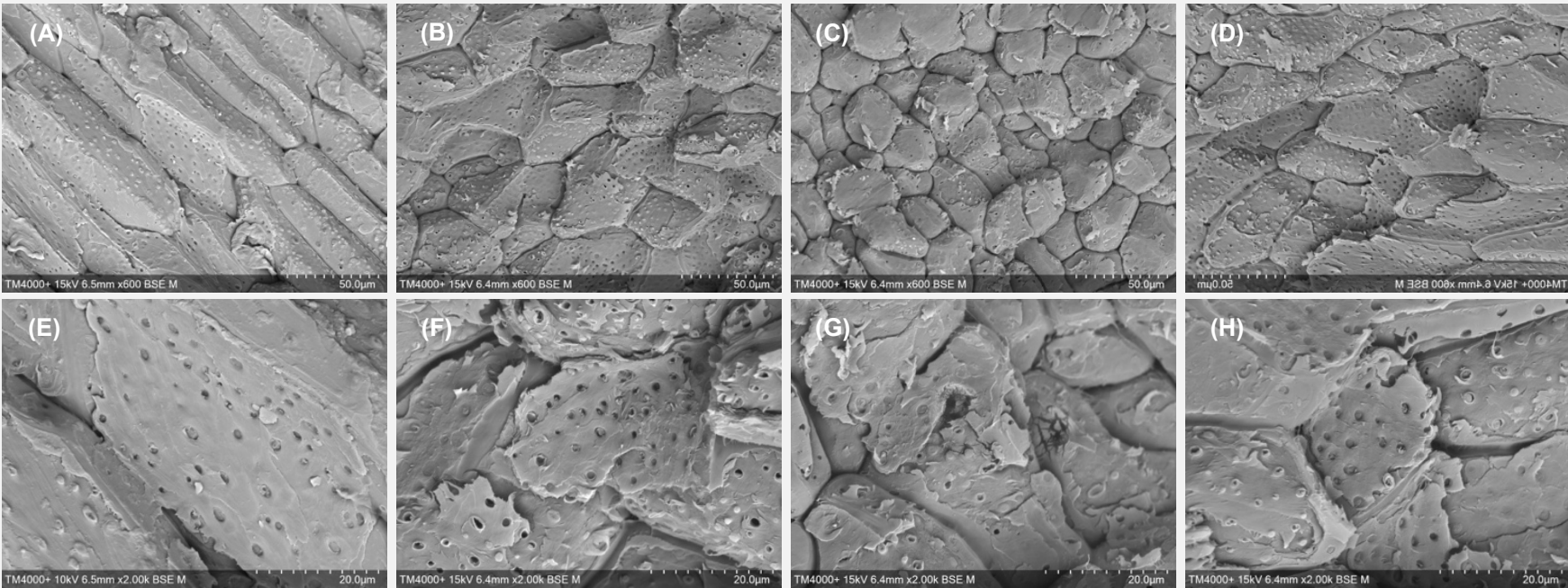

*Figure 17 - Scanning electron micrographs of vertical cross-section of hazelnut shells at 600x (A-D) and 2000x (E-H). (A, E) untreated; (B, F) 40 °C; (C, G) 105 °C; (D, H) photovoltaic-dried.*



## Topics to cover



1. Literature review

2. Hot-air drying

3. Solar drying lab scale

4. Next steps

## NEXT STEPS

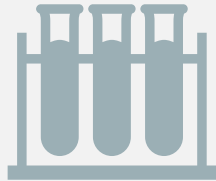

Analyzing lab scale drying results, draft a research manuscript for journal submission.



Optimise the dryer design using computational fluid dynamics simulation.



Consider larger scale of trials in 2026 or 2027.



Rapid moisture analyser modification to suit hazelnuts.

# Acknowledgement



- Marcelo III Dela Cruz
- Pavittar Singh
- Xinran Gao
- Cordelia Selomulya



Special thank to Dr. Basil Baldwin for providing hazelnuts samples, discussion on drying process, and inspirations!



Charles Sturt  
University

